



# Principal Design Manager (m/f)

Full time | Chalgrove, Oxfordshire, Gran Bretaña

## #yourmission

To Carry out design coordination of Knapp UK projects in-line with the Construction Design and Management Regulations 2015.

### Key Responsibilities:

- Carry out the duties of the Principal Designer in line with the requirements of the CDM Regulations 2015
- Engage with clients and designers to positively influence, enhance and integrate health & safety / design risk management into the project team, design team meetings and the construction phase
- Take ownership and lead the design risk management process whilst applying the general principles of prevention
- Effectively plan, manage, monitor and coordinate health and safety during the pre-construction phase when most design work is carried out.
- Take account of various aspects of the project including usability, functionality, future maintainability, life cycle building management and identify residual risks at all stages of the project
- Identify, compile and issue suitable project specific pre-construction information to assist contractors in managing significant risk once construction begins
- Health & Safety File compilation.
- Provide clear, concise and practical health and safety advice, guidance and coaching to project teams at all stages of the project when required.
- Management of multiple projects for key clients to the business

## #yourareknapp

### Professional & Experience requirements:

- Hold a NEBOSH Construction Certificate ? Valid within the last 5 years
- Technical, Graduate or Chartered Membership of IOSH
- Hold a design qualification. i.e. engineer or relevant experience preferably in a Materials Handling Environment



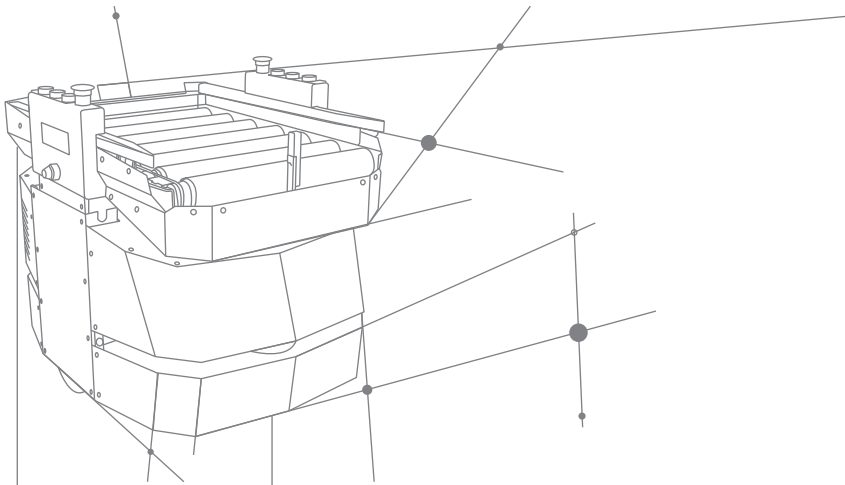

- Full clean driving license

#### Experience and personal requirements:

- Must have extensive experience & knowledge of construction design process
- Previous CDMC experience (CDM 2015)
- Experience of working as a Health & Safety Advisor within the construction industry
- Automation experience
- Computer literate (Excel/Word/Outlook)
- Good time management
- Ability to work autonomously
- Ability to communicate effectively verbally and in writing with both clients and contractors
- Ability to manage workload efficiently
- Effective decision maker and excellent team player
- Commitment to company's Equality and Diversity policies and values

#### Emotional requirements:

- Motivation / dependability / appearance / business trips: Positive, constructive, and self-confident attitude towards the company and towards position (role model for colleagues and representative of the company) Ability to form own opinion and make decisions in pressure situations and can see through these decision to completion. Sales-oriented appearance. Willing to travel frequently in country and abroad for business trips.
- Internal and external perceptions / creativity: Can understand one's role as well as the role of the business partner, even in difficult situations, to find sustainable solutions.
- Communication and work relationships: Able to communicate well with various groups of people, is able to see things from the perspective of others, and can deal sensitively with customers and contractors.
- Economic thinking: Able to act and thinks economically, and handles resources responsibly.
- Reliability: Adheres to performance targets agreed upon and promises.
- Skills in conflict: Able to identify tensions, openly address problems, deal with any conflicts and to provide viable solutions.



