

Engineering Team Leader (m/f)

full time | Castle Donnington, Gran Bretaña

Overview of the role:

- To support the Knapp Site Engineering manager/ Supervisor in their duties in providing a highly available automation system
In conjunction with Knapp UK technicians, provide a first class site response to the customer, ensuring as far as reasonably practical a first time right policy.
Involvement in meetings as and when required, both with the customers and Knapp UK.
Provide emergency breakdown and maintenance support. On all equipment and software issues on the installed equipment
Be part of the Issue Management and the internal escalation process on all related maintenance issues, in partnership with the customer.
Create strong effective working relationships with our customers and your responsibility team, to enable Knapp to provide a first class service.
Provide performance in terms of controlling maintenance activities on site, speed of response and quality of repair and standards of workmanship.
To provide maintenance support on other issues as well as the installed system, when requested to work on these items when work loading permits.
To co-ordinate a team of site technicians and third party repair companies on their activities on site.
- To support the Knapp Site Engineering manager/ Supervisor in their duties in providing a highly available automation system
- In conjunction with Knapp UK technicians, provide a first class site response to the customer, ensuring as far as reasonably practical a first time right policy.
- Involvement in meetings as and when required, both with the customers and Knapp UK.
- Provide emergency breakdown and maintenance support. On all equipment and software issues on the installed equipment
- Be part of the Issue Management and the internal escalation process on all related maintenance issues, in partnership with the customer.
- Create strong effective working relationships with our customers and

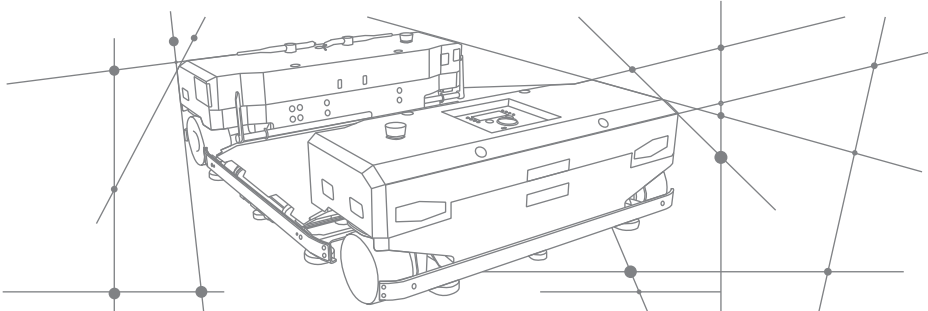

your responsibility team, to enable Knapp to provide a first class service.

- Provide performance in terms of controlling maintenance activities on site, speed of response and quality of repair and standards of workmanship.
- To provide maintenance support on other issues as well as the installed system, when requested to work on these items when work loading permits.
- To co-ordinate a team of site technicians and third party repair companies on their activities on site.

Key Responsibilities:

- Maintain Quality of Service by ensuring good quality communications between both customers and Knapp.
Ensure that reports are well written and legible.
Implementation of Site quality procedures, safety procedures, and any statutory procedures.
Regular meetings with the Site Engineering Manager of Knapp UK, and Knapp head office service coordinator to discuss activities and progress.
Involvement with suppliers ensuring their maintenance visits are kept up to date.
Providing maintenance service support, to the installed system.
Ensure that all spares issues are dealt with efficiently and rapidly.
Ensuring the company equipment supplied is well cared for and is always in a presentable/usable/maintained condition.
Provide flexibility and the best use of skills and capabilities of the maintenance team on site
Ensure that all time sheets and documentation is correct and legible with all the correct job numbers entered.
- Maintain Quality of Service by ensuring good quality communications between both customers and Knapp.
- Ensure that reports are well written and legible.
- Implementation of Site quality procedures, safety procedures, and any statutory procedures.
- Regular meetings with the Site Engineering Manager of Knapp UK, and Knapp head office service coordinator to discuss activities and progress.
- Involvement with suppliers ensuring their maintenance visits are kept up to date.
- Providing maintenance service support, to the installed system.
- Ensure that all spares issues are dealt with efficiently and rapidly.

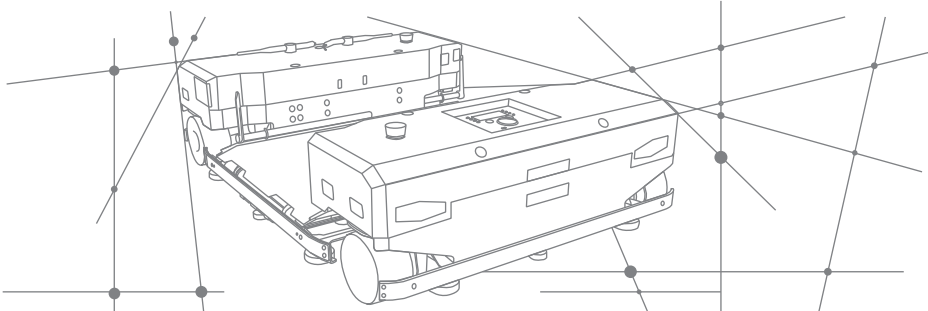

- Ensuring the company equipment supplied is well cared for and is always in a presentable/usable/maintained condition.
- Provide flexibility and the best use of skills and capabilities of the maintenance team on site
- Ensure that all time sheets and documentation is correct and legible with all the correct job numbers entered.

Qualifications/Experience:

- HNC/HND/ONC Apprenticeship/BTEC, City and Guilds in appropriate subjects. Electrical & Mechanical Engineering.
- Knowledge and understanding in Control software at PC and PLC level
- Minimum 5 years' experience in a relevant industry or service.
- Ability to communicate clearly verbally, clear concise writing skills
- Demonstrable experience in man management
- Experience of having operated a CMMS system preferred.

Candidate profile:

- Team oriented
- Customer focused
- Reliable
- Self-motivated
- Ability to 'think on their feet'
- Flexible in hours worked
- Able to take ownership of situations
- Good interpersonal and communication skills
- Good organizational skills
- Physically fit and able to work at height