

## Shift Engineer (m/f)

Full time | Corby,

### Job Summary

It is expected that all Engineers will possess proven experience of dealing with electro-mechanical faults and preventative maintenance operations within a warehouse environment.

Reporting to the Site Manager/Supervisor, the Engineer will be eager though safety conscious, with a track record of owning problems and taking them through to successful completion. Every team member will be required to respond out of hours in an emergency situation. This emergency cover will be scheduled within the team and is not a permanent requirement. European travel for training may be required.

### Key Responsibilities

- Mechanical strip-down/re-assembly, basic field wiring, machine calibration and system testing.
- Day to day maintenance of site MHE to a high standard,
- Accountable for managing time via CMMS to achieve over 90% utilisation
- Look to continuously improve all aspects of new and old equipment, be health and safety conscience.
- Work against timeframes to complete reactive repairs.
- Interact with on-site management keeping them informed of repair and maintenance progression and address their concerns in a professional manner.
- Service and repair current installed products and demonstrate hands on ownership of issues to achieve a fast resolution.
- Able to interpret electrical circuit diagrams and work with 415V motor controls.
- Appreciate Health & Safety considerations and be able to carry out risk assessments
- Mechanical aptitude including the ability to read assembly drawings
- Operate hand tools and be able to assemble parts onto equipment
- Able to follow set up instructions, assembly drawings and check lists
- Attention to detail and exceptional follow-up skills
- Excellent customer service skills for both internal and external customers
- Appreciation of control systems
- Be willing to learn and adapt to changing role requirements

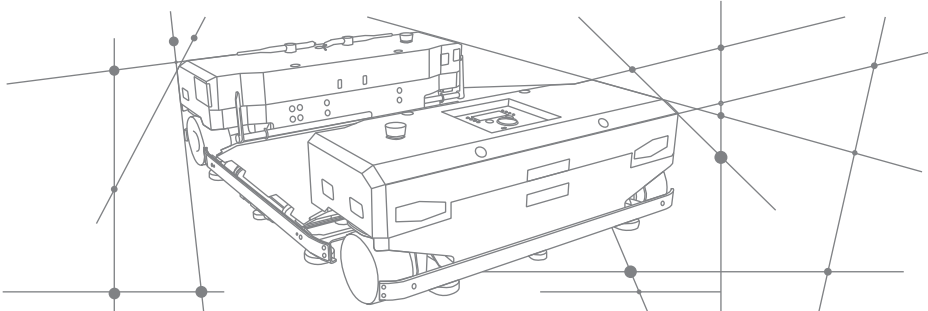

- Appreciation of Cultural Diversity
- Able to communicate effectively with stakeholders at all levels both internally and within the customer organisation
- Able to effectively present a KPI based monthly review to key stakeholders

### Qualifications, skills and experience

- NVQ/BTEC/C&G Level 3 in an Electro-Mechanical Engineering discipline
- Understanding of Non-Destructive Technologies and Testing
- Understanding of PLC's and their function
- Pneumatic and Hydraulic knowledge beneficial.
- Computer literate with basic Microsoft Office skills.
- Use of CMMS system and engineering stores
- HNC/HND equivalent is desirable

### Important behaviours to have in line with our company values

- Appreciation ? Recognises the achievement of others
- Creativity ? Is resourceful and innovative
- Courage ? Willing to learn and try new things
- Openness ? Always approachable and helpful
- Reliability ? Consistently gives their best

### Company benefits

- KNAPP will contribute up to 6% pension
- Private healthcare with Vitality
- Cycle to work scheme
- Employee referral scheme
- Employee assistance programme
- Employee of the Quarter awards